

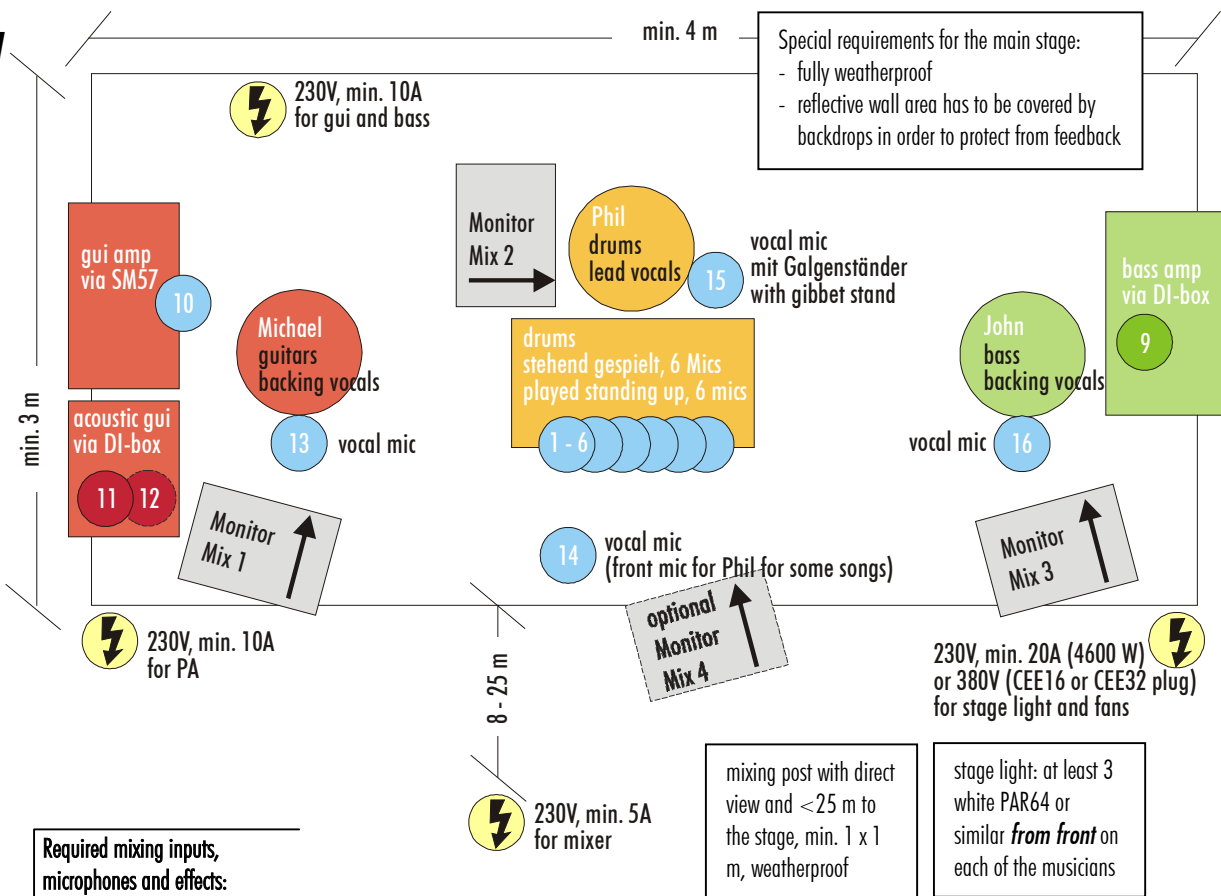

Technical Rider

Rel. 4.3e



Required mixing inputs, microphones and effects:

pls. note: * = provided by the band, unless when travelling by plane (pls. refer to instrumental rider in this case)

Channel	Muco	MiniMuco*	Instrument	Mic*	Insert
1	1	1	kick	Beta 52A*	gate
2	2	2	snare	SM57*	comp [optional]
3	3	3	tom low	Beta 98AMP*	
4	4	4	tom high	Beta 98AMP*	
5	5	5	ride	Beta 27* [underhead mount*]	
6	6	6	hi-hat/crash	Beta 27* [underhead mount*]	
7	7				
8	8				
9	9		e-bass	DI box*	comp
10	10		e-guitar	e906*	comp
11	11		acoustic guitar 1	DI box*	
12	12		acoustic guitar 2 [optional]	DI box [NOT provided by band]	
13	13	7	lead vocals front Phil	Super 55 Deluxe*	comp
14	14		backing vocals Michael	55SH Series II*	comp [optional]
15	15	8	lead vocals Phil	55SH Series II*	comp
16	16		backing vocals John	55SH Series II*	comp [optional]
Master L	17 / R1				31-Band EQ 1
Master R	18 / R2				31-Band EQ 2
Aux 1 [PreFade]	19 / R3		monitor mix 1 Michael		31-Band EQ 3
Aux 2 [PreFade]	20 / R4		monitor mix 2 Phil		31-Band EQ 4
Aux 3 [PreFade]	21 / R5		monitor mix 3 John		31-Band EQ 5
Aux 4 [PreFade]	22 / R6		monitor mix 4 Phil front [optional]		31-Band EQ 6
Aux 5 [PostFade]			effects - light reverb	on snare	reverb
Aux 6 [PostFade]			effects - mainly delay (slapback) and reverb	on vocs [e.g. tc M-ONE #130 and #001]	several effects